

APPLICATION OF NEG ARG FIBRE

Nippon Electric Glass
Ref. No. 007

GFRC in the San Francisco Marriott Hotel



Glass fiber reinforced concrete (GFRC) is a cost-effective cladding system. It provides wide opportunities for architects and their creative talents. Because of its light weight, unique geometric shapes can be produced without the penalty of heavy section thickness and the resulting increase in weight.

GFRC is most popular with new construction, such as the San Francisco Marriott Hotel, completed in 1989. Built at an approximate cost of \$200 million, it is 42 stories tall and has 1,500 guest rooms. The Marriott is the largest GFRC project of its kind in the U.S. and required 2,400 panels, totaling 340,000 sq. ft. of surface area. [The largest previous application of GFRC was the 180,000 sq. ft. (16,740 m²) Ramada Renaissance Hotel located in San Francisco and manufactured by Lafayette Manufacturing, Inc.]



One of the primary advantages of GFRC is its light weight. When combined with a steel stud frame, the approximate weight is 20 pounds per sq. ft. (98 kg/m²), which is approximately one-quarter the weight of regular architectural precast panels. In the case of the Marriott Hotel, typical wall panel sizes were 10 ft. in height by 18 ft. in length (3.05 x 5.49m), but weighed only 3,600 pounds. GFRC thus spared the expense of 100 to 150 tons of structural steel. The light weight also saves money in lifting equipment and labor costs.

Mr. Edward S. Knowles, vice president of Lafayette Manufacturing Inc., the manufacturer of GFRC, spoke on the construction work in the PCI Journal:

"The types of GFRC units consist of window wall panels, solid wall panels, spandrel panels and column covers. The window wall panels and solid wall panels are approximately 10 ft. in height by 18 ft. in length (3.05 x 5.49m). The spandrel panels are about 5 ft. in height by 18 ft. in length (1.52 x 5.49m) and the column covers are approximately 10 ft. in height by 3 ft. in width (3.05 x 0.91m). The panels varied in thickness from 8 to 24 in. (203 to 610 mm).

"The panels are comprised of a GFRC skin, with an architectural face mix, attached to a 6 in. (152 mm) steel stud frame. Fig. 1 shows a GFRC skin configuration and Fig. 2 shows a steel stud frame configuration. Figs. 1 and 2 are for a window wall panel.

"The steel stud frame was fabricated using structural steel tube members and galvanized light gauge steel studs. The steel stud frame stiffens the GFRC skin and provides a surface for the attachment of the interior finishes. The steel stud frame also provides support for the attachment of the glazing system and the

louvers.

"Bearing connections, either angle or structural tube, were welded to the structural tube members of the steel stud frame. These connections were attached to steel floor beams in pockets in the concrete floor slab. Lateral (or push/pull) connections were all thread rods, threaded into nuts welded to the structural tube members. These connections were bolted to angles, structural tubes or channels, welded to either the bottom of the floor beams or the steel columns. Figs. 3 and 4 show panel sections detailing the connections to the structure."

In addition to design flexibility, GFRC has demonstrated its superior quality and performance in many buildings and other applications. Mr. Knowles concluded his discussion of GFRC as follows:

"The structure and the GFRC cladding panel system performed very well during the recent Loma Prieta earthquake on October 17, 1989. While the interior furnishings and finishes were damaged during the earthquake, the exterior facade exhibited no signs of structural distress. This demonstrates the success of the application of the GFRC cladding panel system in high seismic zones, such as California."

(Henry J. Molloy, Molloy and Associates, Inc.)
(January, 1992)



San Francisco Marriott Hotel

Location: San Francisco, California, USA

Owner and General Contractor: Marriott Corporation, Washington, D.C.

Architect: Daniel, Mann, Johnson & Mendenhall, San Francisco, California, USA

GFRC Manufacturer and Installation: Lafayette Manufacturing Inc.

Fig. 1 GFRC Skin Drawings for Window Wall Panel

Fig. 2 Steel Stud Frame Rear View and Sections for Window Wall Panel

Fig. 3 Window Wall Panel Section

Fig. 4 Spandrel Panel Section

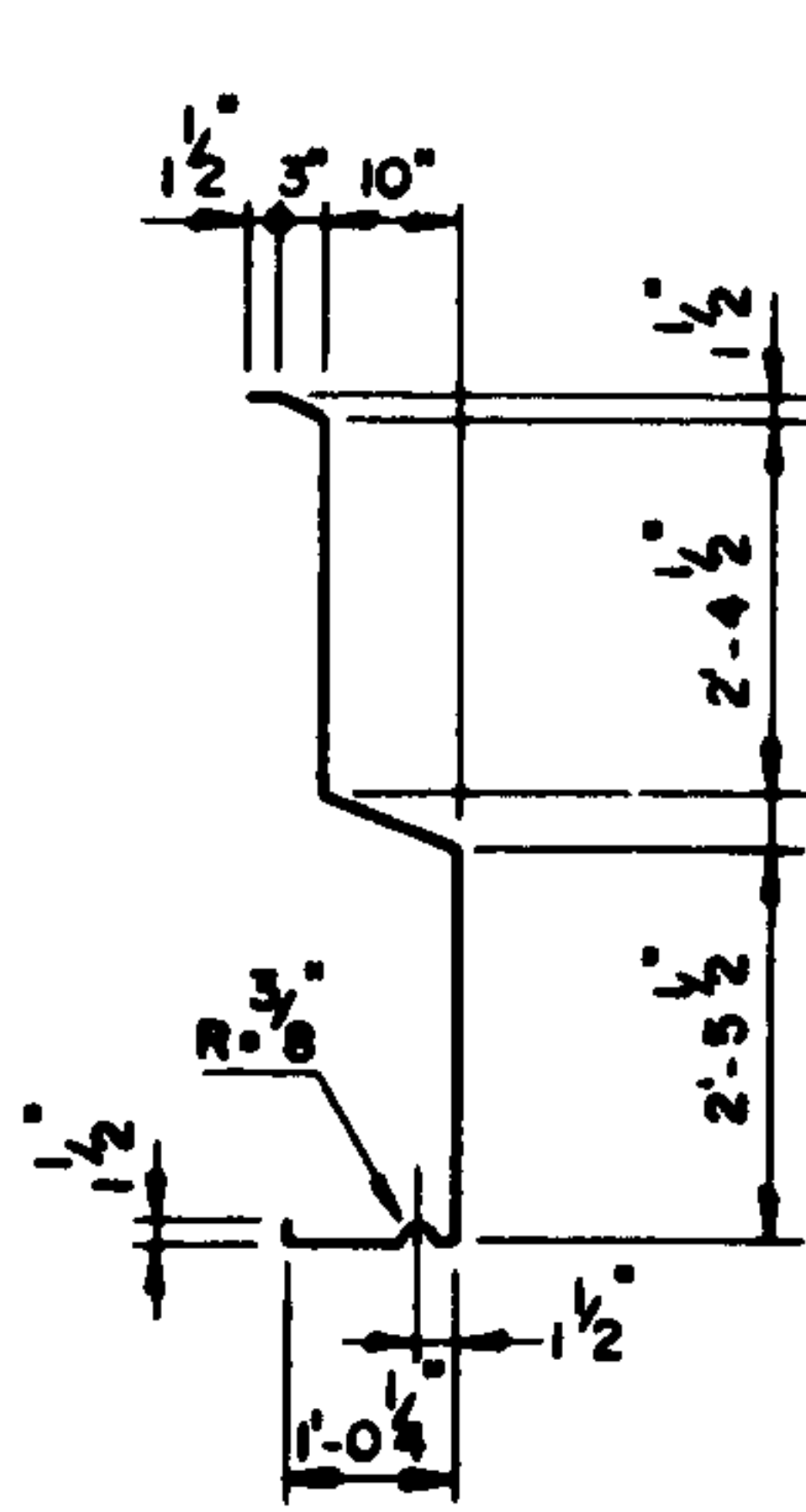

Section A

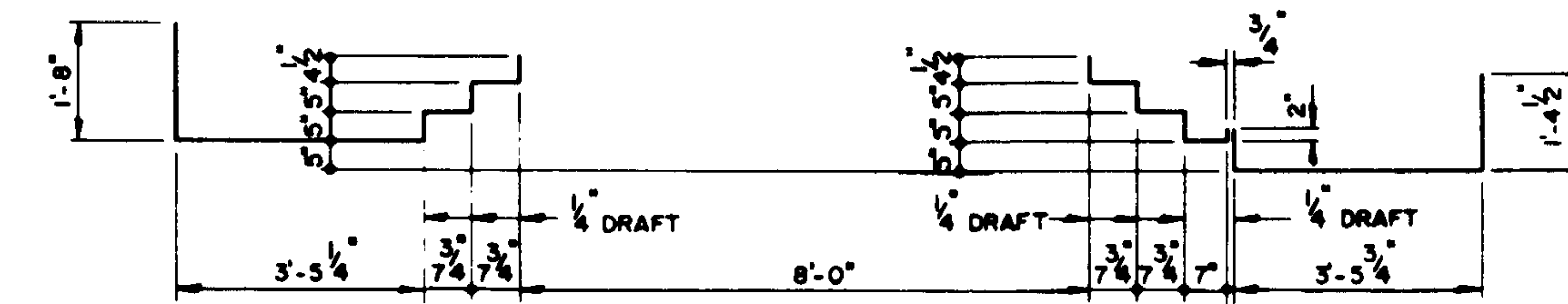

Section B

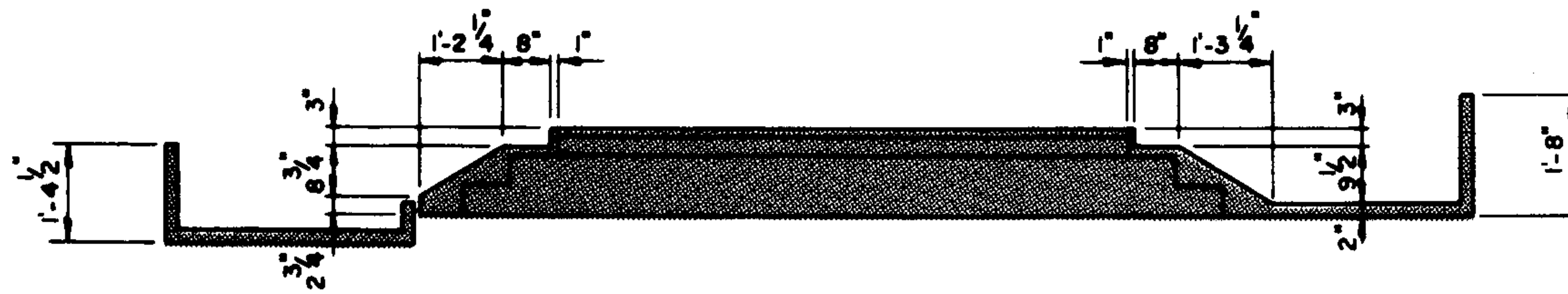

Top View

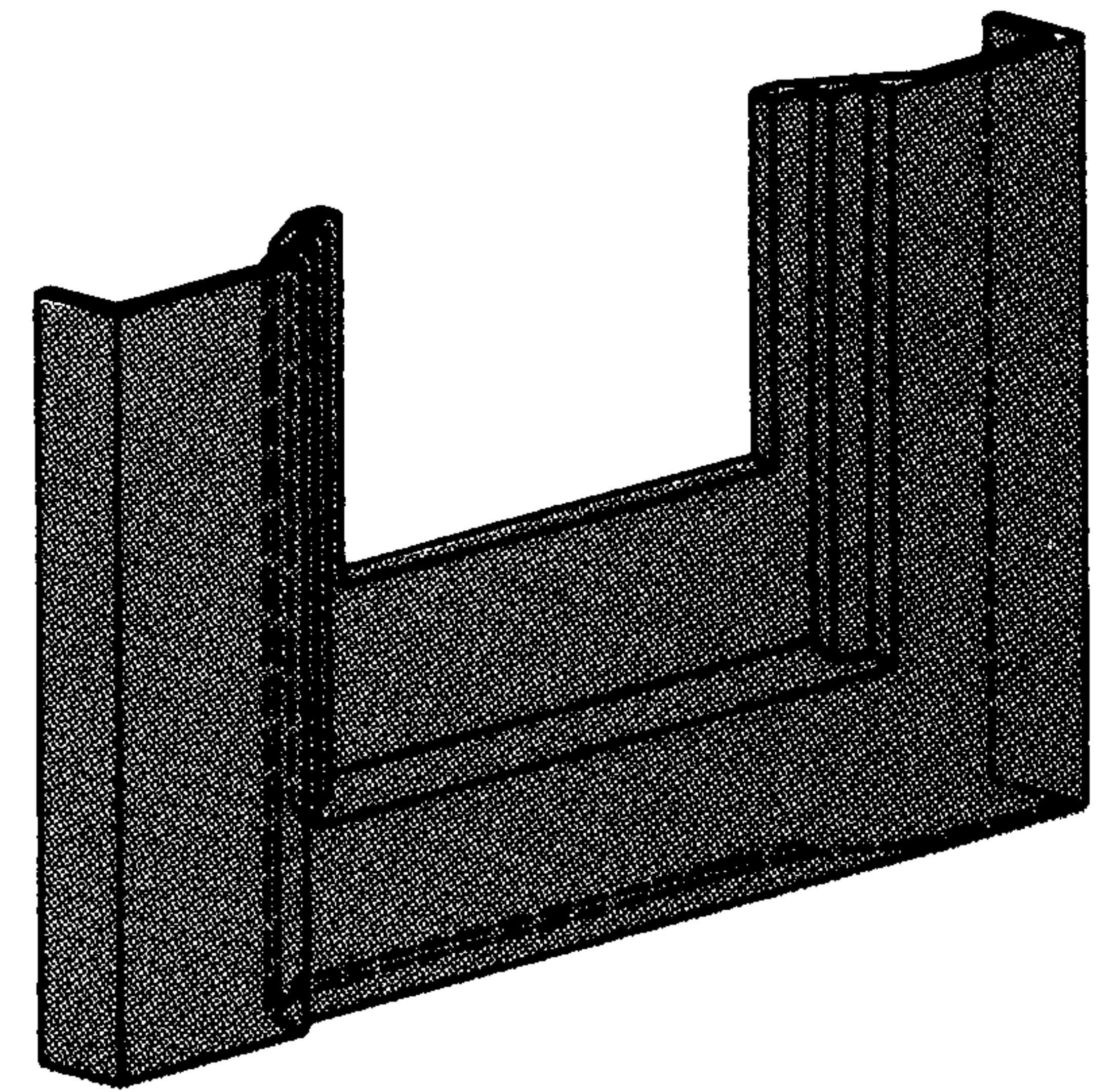

Iso. View

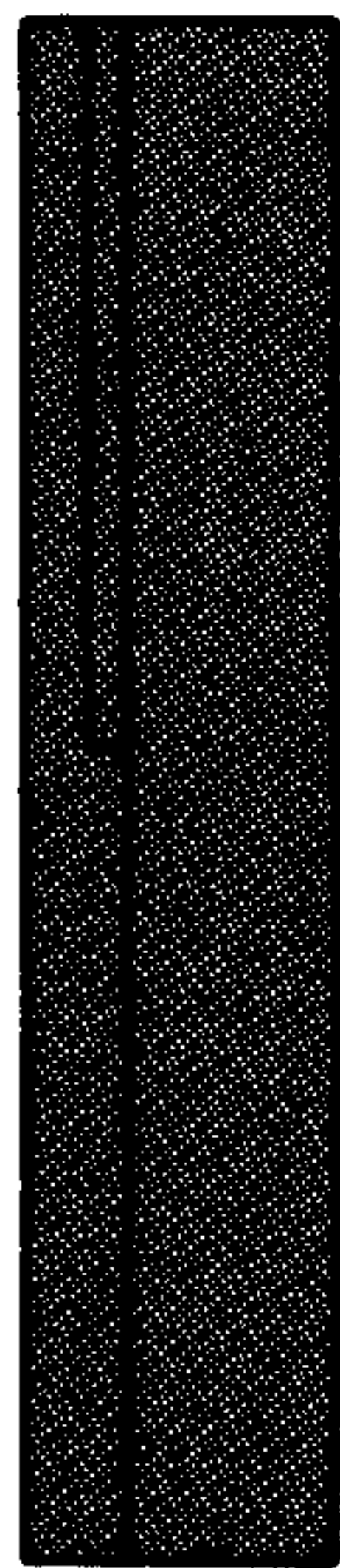

Left

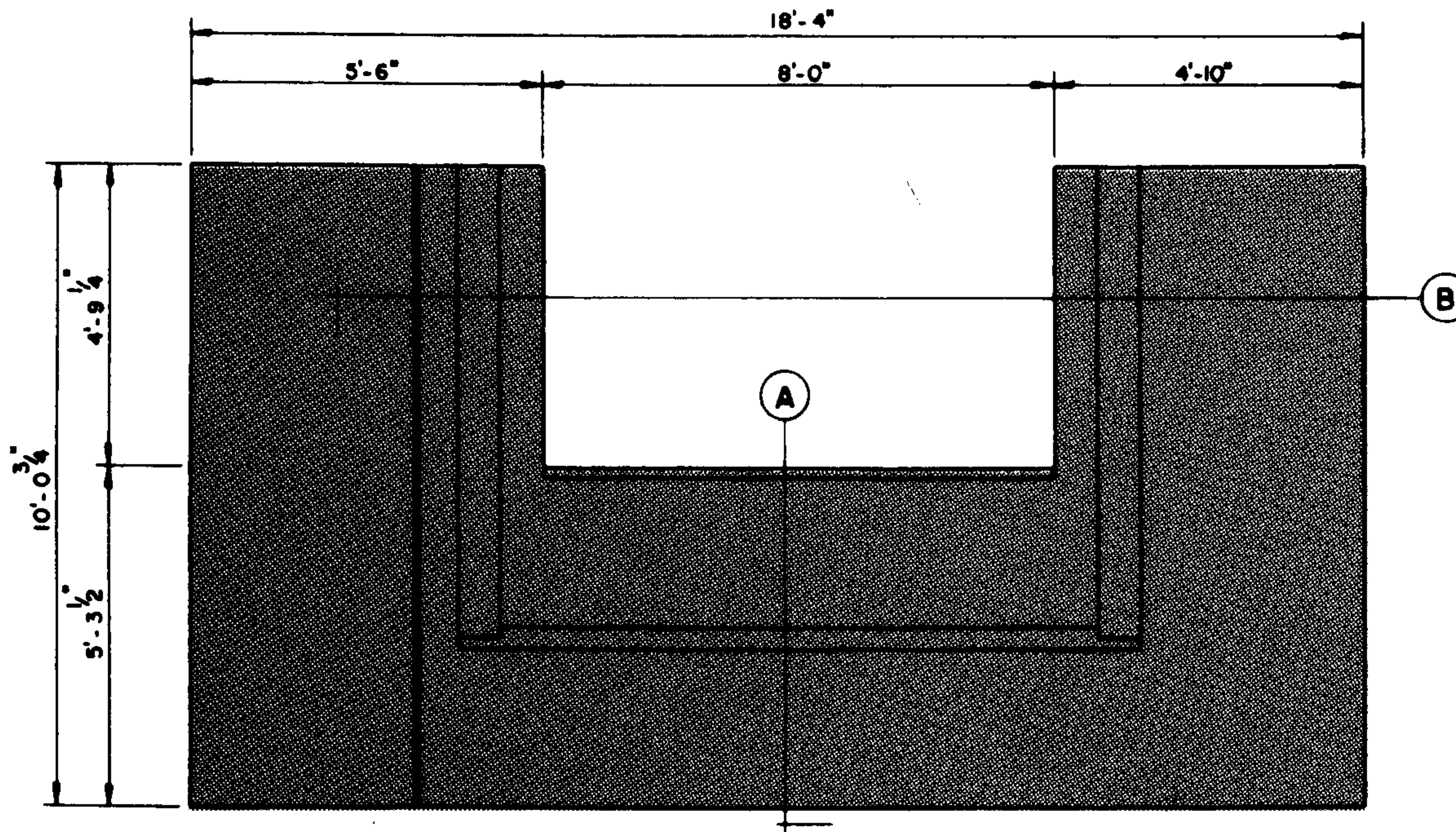

Front View

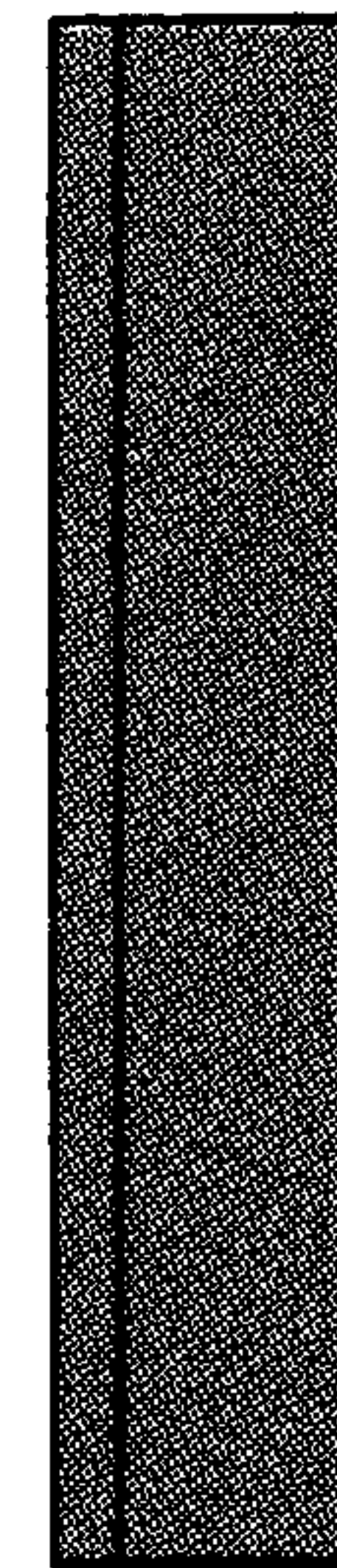

Right

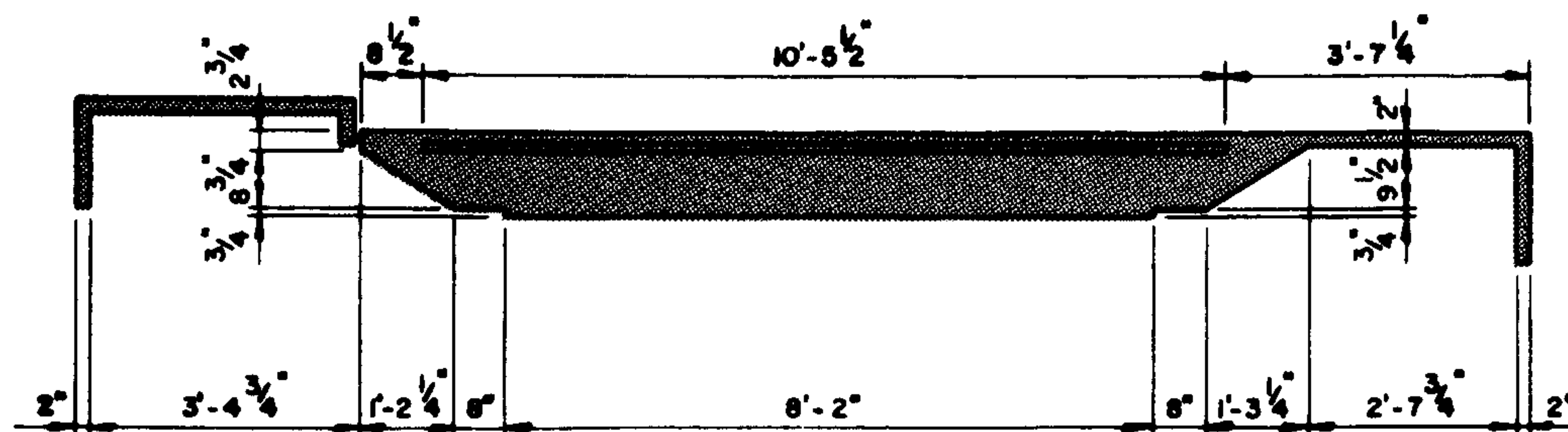

Bottom View

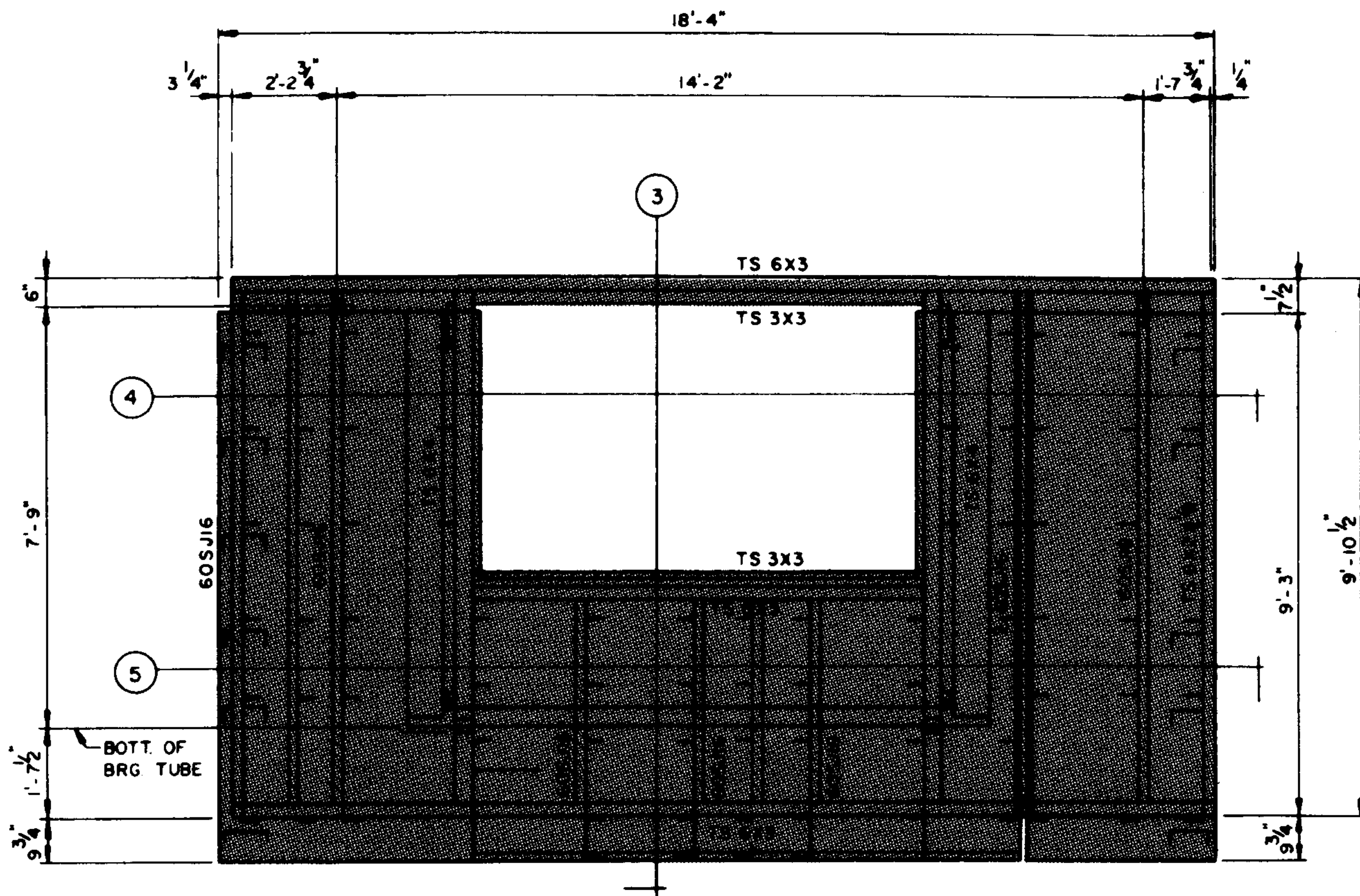

Rear View

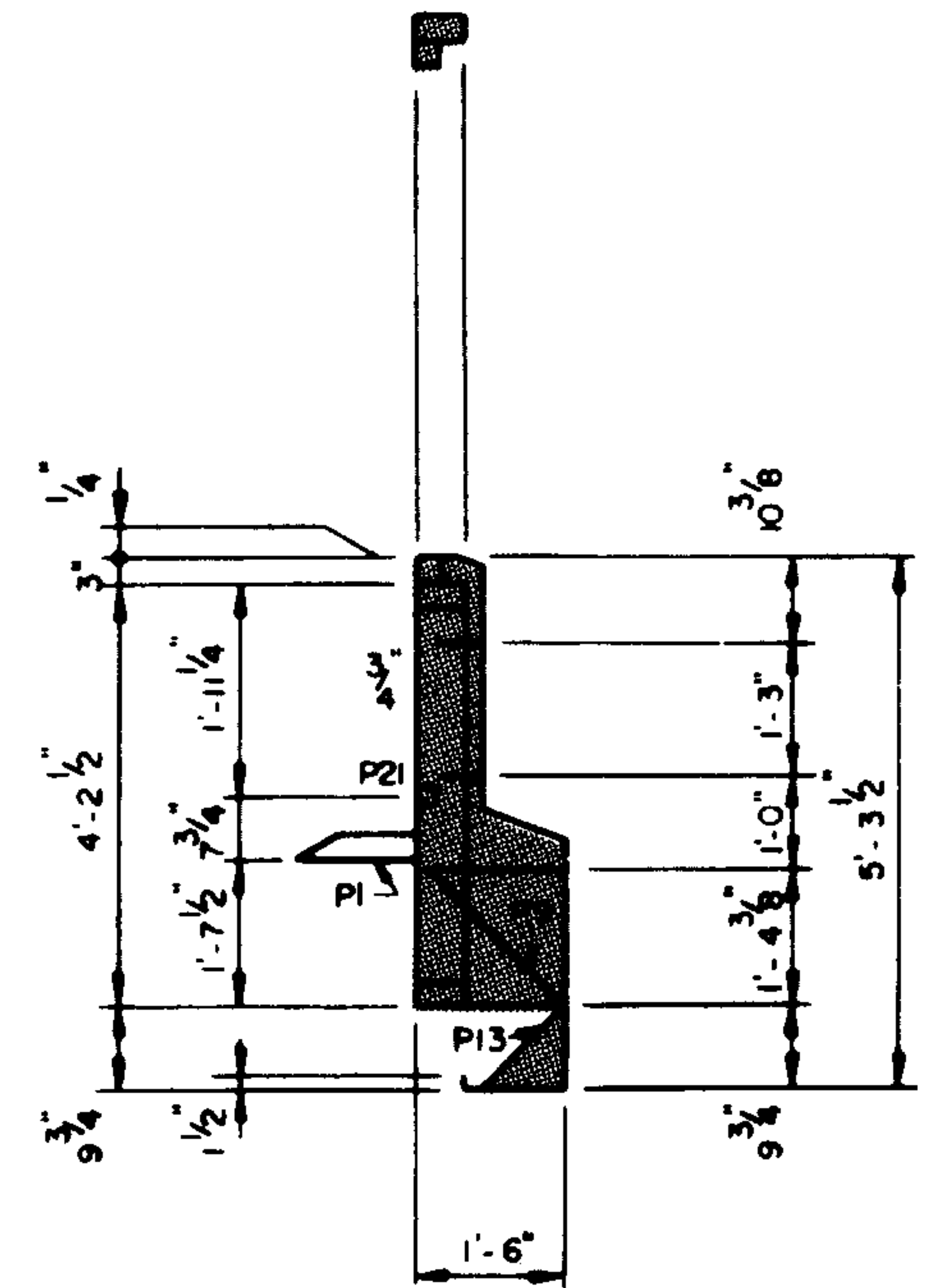

Section 3

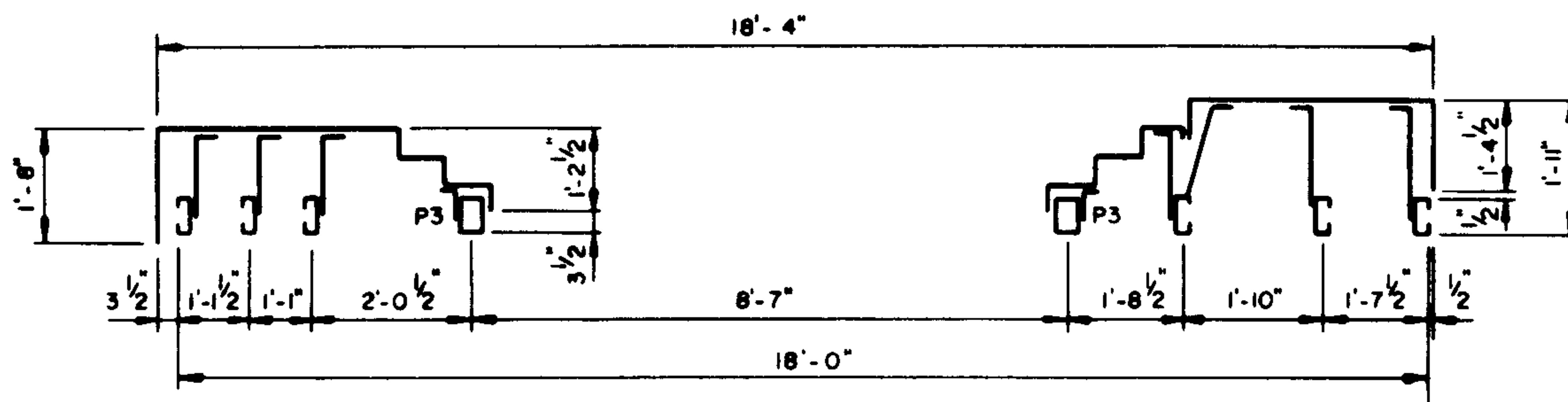

Section 4

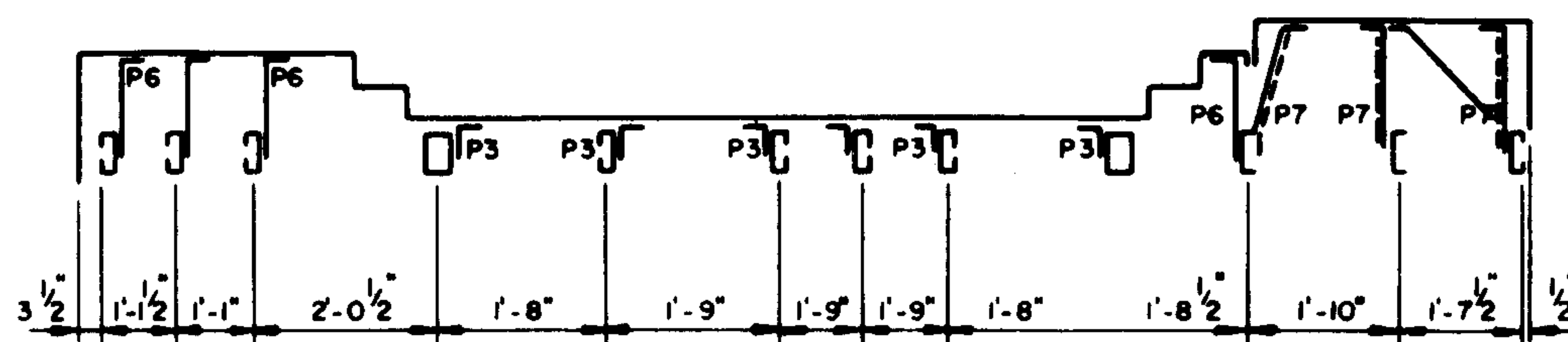

Section 5

